

CALIBER[®] V-Front Ramp Shield Adapter kit for Triton Double Axel

Installation Instructions for Part No. CA0212

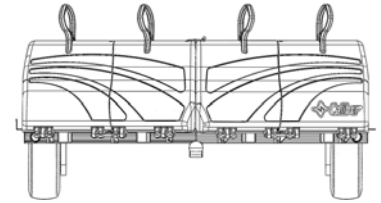

TOOLS REQUIRED:

- Power Drill and 7/32" Drill bit
- Pop Rivet Gun
- 7/16" wrench and ratchet
- Hand Screwdriver

HARDWARE INCLUDED:

Qty	Description
2	Long Slotted replacement SS brackets
2	Short Slotted replacement SS brackets
1	Flexible Rubber Strap kit with rivets
1	Jack Stand relocation bracket
6	1" Self Tapping Hex Head Screws
4	7/16" Hex Bolts and Lock nuts

READ ALL INSTRUCTIONS CAREFULLY PRIOR TO INSTALLATION

STEP 1: Replace front 2 brackets closest to the nose (center) of the trailer with provided Long Slotted replacement Brackets. Use existing bolts provided with shield hardware kit

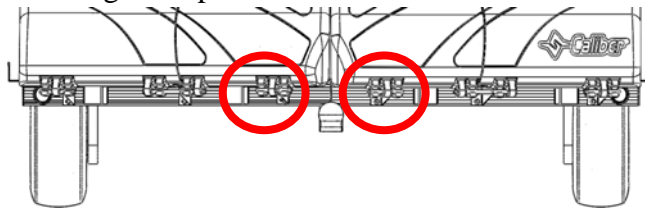
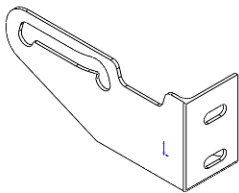

STEP 2: Replace middle 2 brackets in the center of each shield half with the provided Short Slotted replacement SS brackets. Use existing bolts provided with shield hardware kit. Shields existing non-slotted brackets will be used on edge of trailer. Discard remaining for non slotted brackets.

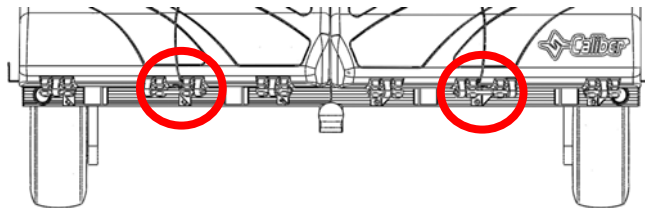
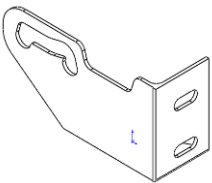

STEP 3: Add Rubber support strap half way up the shield. Exact Location is flexible as long as both strap and receptacle bracket on strap are lined up horizontal. Make sure receptacle bracket curve wraps around inside corner of shield panel. Drill 7/32" holes in the shield and fasten with provided rivets

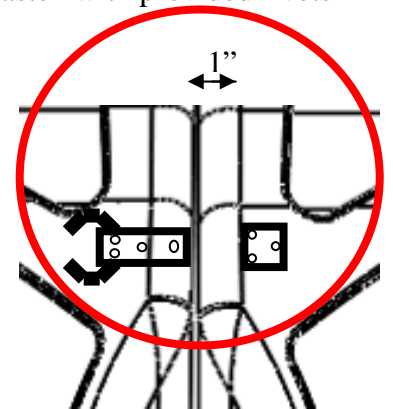
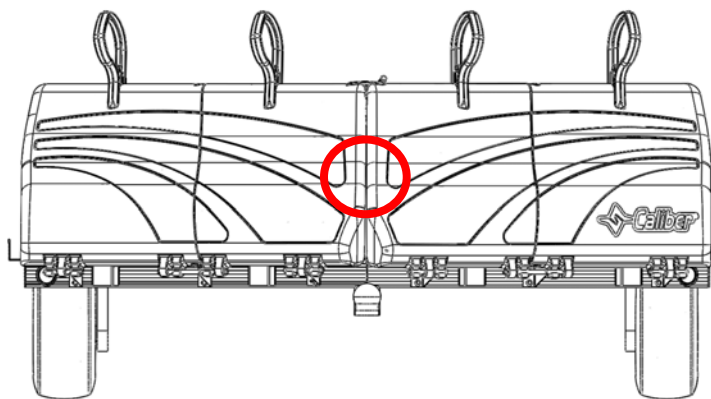

CALIBER[®]

952-985-9999

www.caliberproductsinc.com

STEP 4: Remove Jack Stand from trailer. Next position the jack stand on the plate, align and mark the position for the (4)1/2" holes to be drilled which will be used for the replacement bolts.

HELPFUL HINT: Start with a smaller drill bit and increase bit sizes to 1/2"

STEP 5: Install jack stand relocation bracket as shown. The top edge of the plate **MUST BE FLUSH** with the top edge of the trailer. This relocation of the jack stand will give you clearance to use the jack stand and the shield. Note: Jack stand must be in the down position when using the ramp. Mount jack stand plate by pre-drilling 6 1/4" holes into the plate as shown. Use the 6 provided self tapping screws to mount plate to the trailer.

HELPFUL HINT: Pre-drill pilot holes into the trailer for the self tapping screws using a 5/32" bit.

STEP 6: Mount the jack stand with provided 7/16th bolts and lock nuts. Tighten everything and rotate positions of shield and jack stand to confirm all clearances.

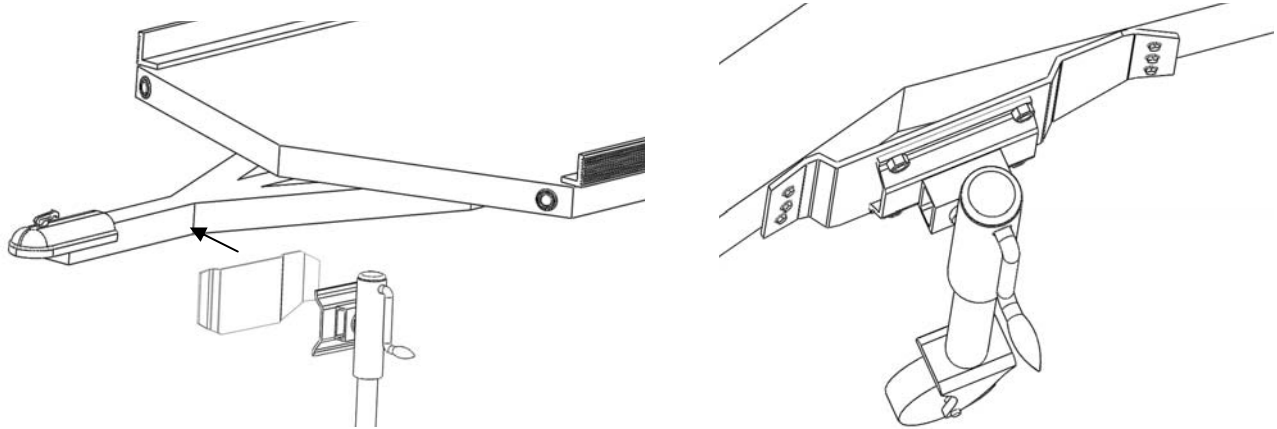

WARNING: Do not stand behind Snowmobiles or ATV's when loading/unloading. Always load Snowmobiles and ATV's at low speeds using extreme caution.

CALIBER, INC. LIMITED LIFETIME WARRANTY

Caliber, Inc. warrants that this product will be free from defects in material or workmanship under normal use, installation and service. Caliber, Inc. reserves the right, before having any obligation under this limited warranty, to inspect the damaged Caliber product. All warranty shipping costs for inspection shall be borne solely by the purchaser. This limited warranty is non-transferable. Contact Caliber, Inc. at www.caliberproductsinc.com or at 952-985-9999 for warranty service procedures.

DISCLAIMER

Caliber, Inc. shall not be liable for any special, incidental or consequential damages, including, but not limited to, lost revenues, lost profits, personal injury, damage to property, and third-party claims, arising out of any warranty, contract, statutory or tort. Notwithstanding the term of any limited warranty or any warranty implied by law, or in the event that any limited warranty fails of its essential purpose, in no event will Caliber's entire liability exceed the purchase price of this product.

CALIBER[®]

952-985-9999

www.caliberproductsinc.com